

EXPOL REMOVES 99.999% OF ALL LIQUID WATER, OIL EMULSION FLUIDS AND SOLID PARTICULATES FROM COMPRESSED AIR LINES.

expel[®] 3

TECHNICAL INFORMATION



originalAVC

Product Overview

Expel is a revolutionary compressed air filter that protects pneumatic equipment by removing ALL liquid water, oil emulsion fluids and solid particulates down to 1 micron from a compressed air line. Expel does not require any replacement filter elements. Instead, its patent-protected design uses computational fluid dynamics to ensure its performance remains consistent and never drops below 99.999% efficiency.

Performance

- Removes 99.999% of all liquid water, oil emulsion fluids and solid particulates down to 1 micron
- Guaranteed high performance over the lifetime of the filter
- No moving parts that can fail
- No small holes to block or clog

Installation/maintenance

- Easy to install – just fit Expel like a conventional compressed air filter
- No maintenance is required, but the unit can easily be dismantled and cleaned should you want to check it
- The world's first cleanable and reusable compressed air filter
- All spare parts available

Savings

- No replacement filter elements costs
- No consumables or power source required to operate
- No increase in pressure drop as the filter is used

Additional features

- 10-year guarantee
- Designed and tested in accordance with ISO 12500
- Robust stainless steel exterior
- Optional pressure gauge
- Suitable for use in any industry



Operational Specification

Part number	6000-019
Flow rate	1-9 cfm
Operating pressure	1-15 bar(g) / 15-218 psi(g)
Operating temperature	0°C to +80°C / 32°F to 176°F
Maximum recommended inlet temperature	35°C / 95°F
Maximum pressure bar drop at 6 bar	0.1 bar
Liquid water, oil emulsion fluids and solid particulate removal	1 micron

Box Contents

Item	QTY
Expel 3 unit	1
Mounting bracket	1
Mounting bolts	4
Fixing screws	4
Wall plugs	4

Product Details

Inlet/outlet connection	¼" BSPT
Drain connection	½" (m) BSPT
Weight	2.08kg
Product dimensions	170mm x 39mm
Housing material	Stainless steel 316
Internal material	ABS plastic
Quality assurance	Designed and tested in accordance with ISO 12500

Product Dimensions

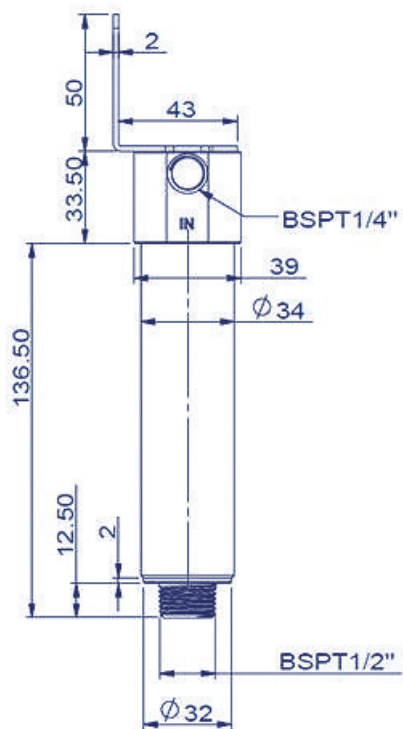
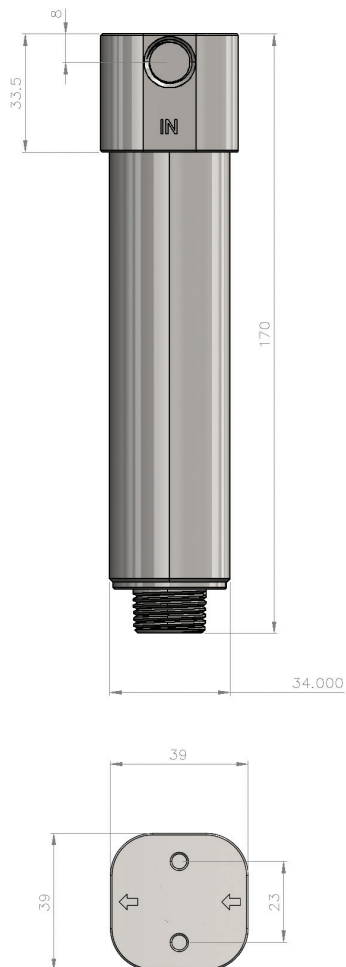

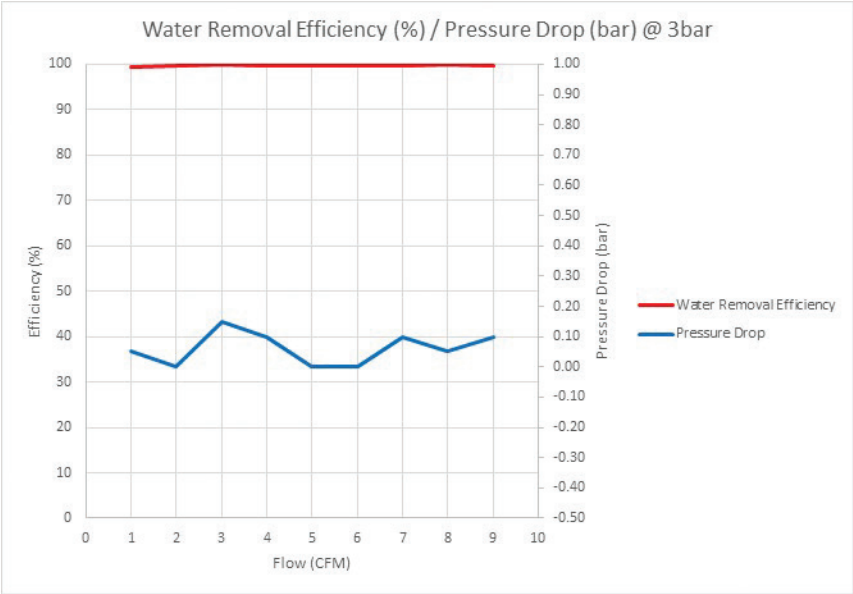
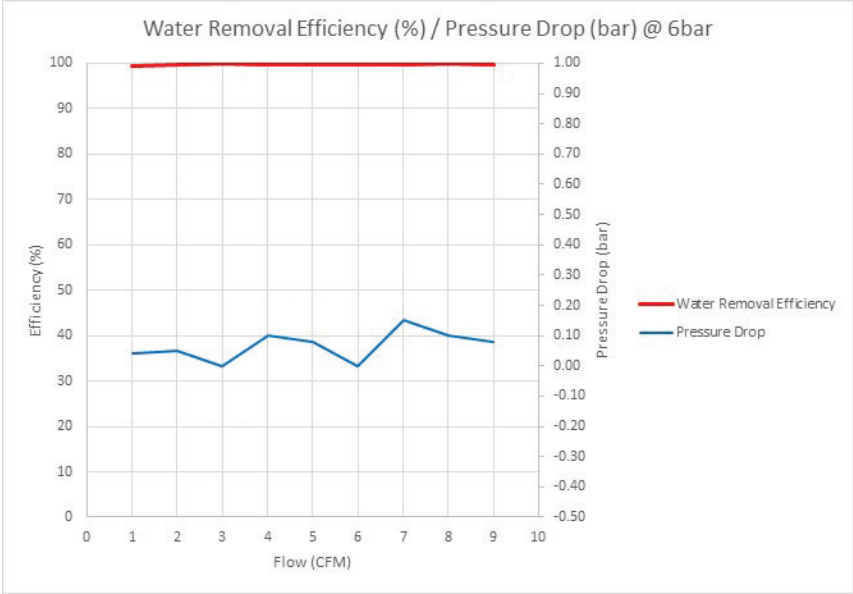



Related Product



Expel Automatic Float Drain

originalAVG

sales@originalavg.com | +44 (0)345 50 50 222 | www.originalavg.com
Unit 52 Atcham Business Park | Shrewsbury | SY4 4UG | United Kingdom

6100-066-AA Expel 3 Booklet – Technical Datasheet